

1140-1/-2

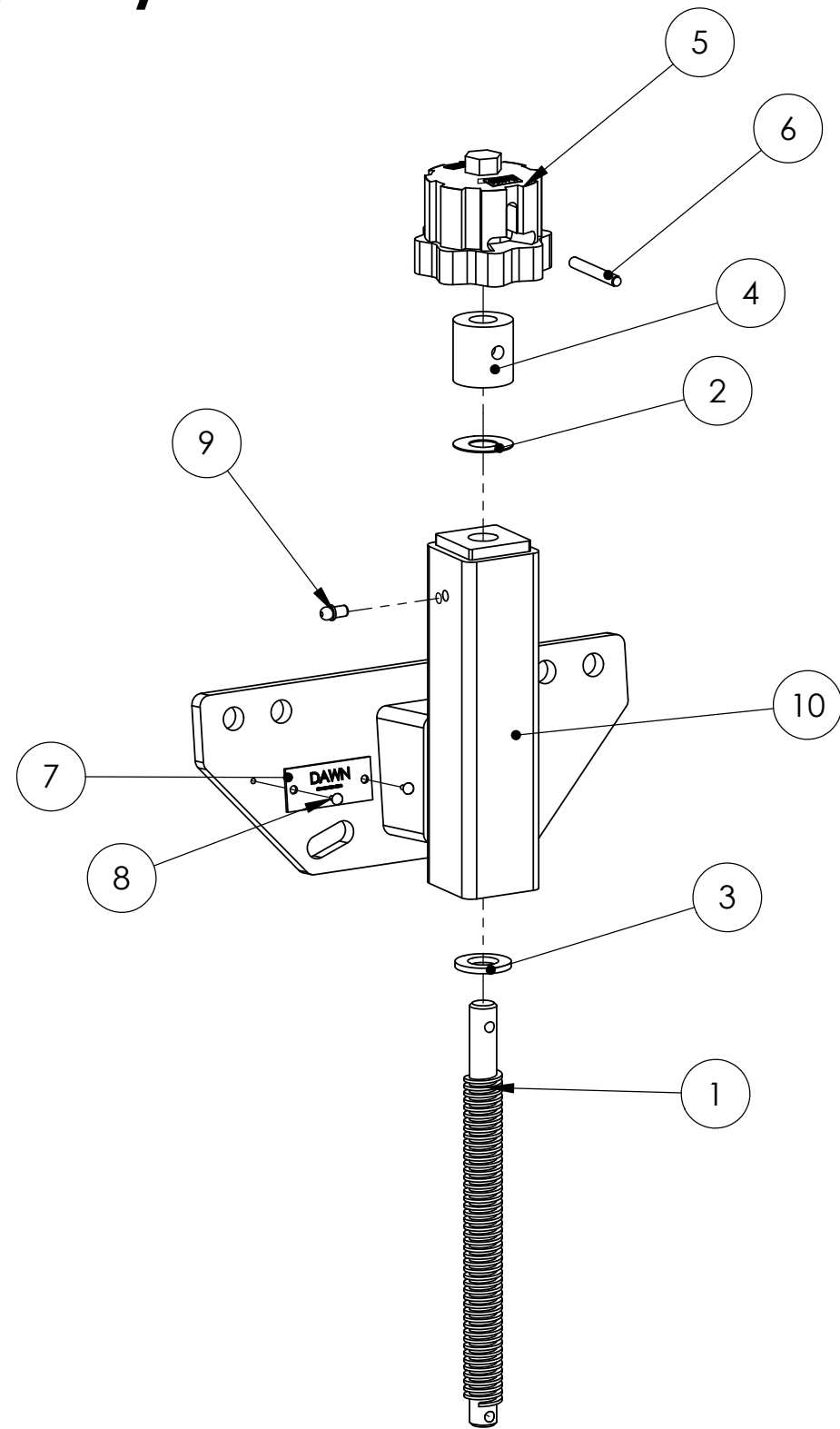

ITEM NO.	PART NUMBER	DESCRIPTION	QTY.
1	100061	SCREW 7/8-6 ACME 10"	1
2	100053	WASHER NYLON	1
3	9032	FW 5/8 X 1.29 X .13	1
4	100035	BUSHING COLLAR	1
5	100046	HANDLE, DEPTH ADJUST(CAST)	1
6	9845	PIN SPIRAL 1/4 X 2 HD	1
7	100043	NAMEPLATE, DAWN	1
8	9041	RIVET, DRIVE	2
9	9806	FITTING, GREASE STR 1/8 NPT	1
10	200348	MOUNT WELDT, 1140-1/2 DUAL	1

1140-2

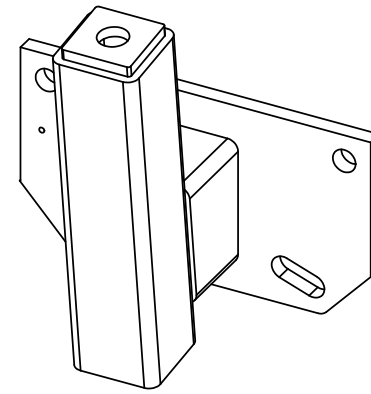

1140-3

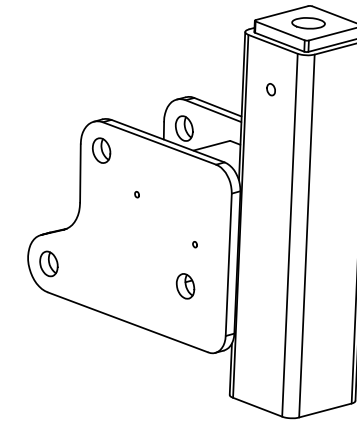

1140-5

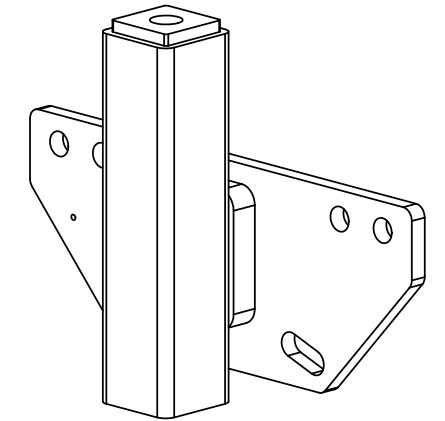

1140W-1/-2

