

# Dawn Model 1202/1203/1204 Curvetine

## Assembly and Operation Manual

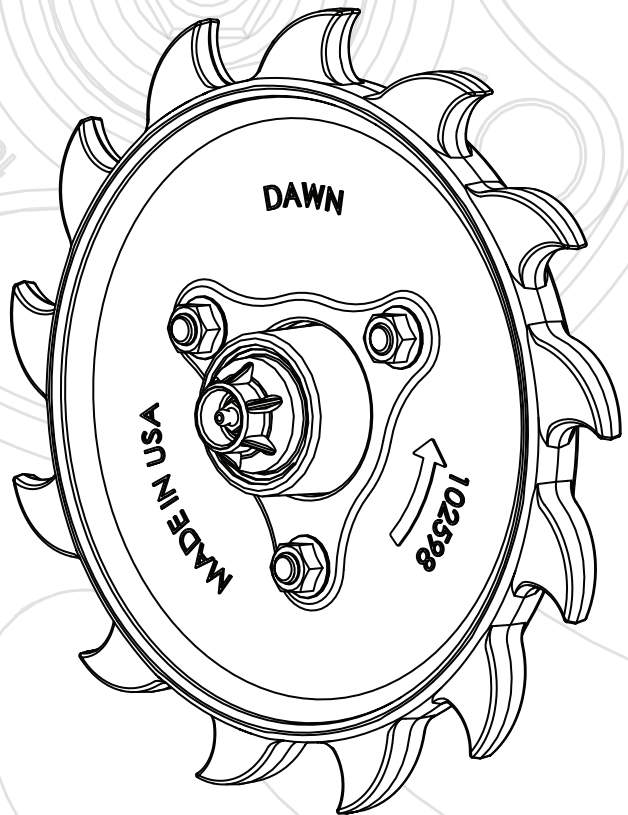
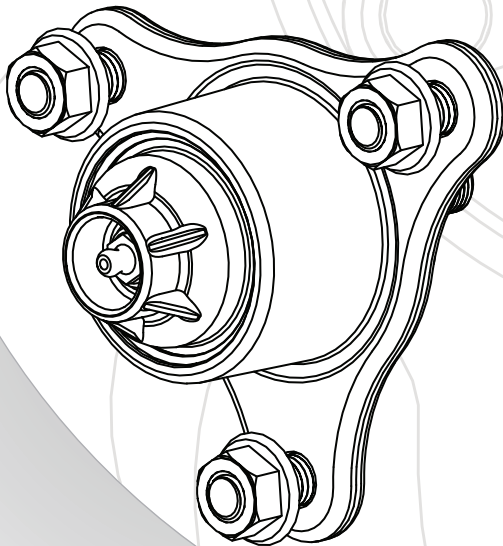
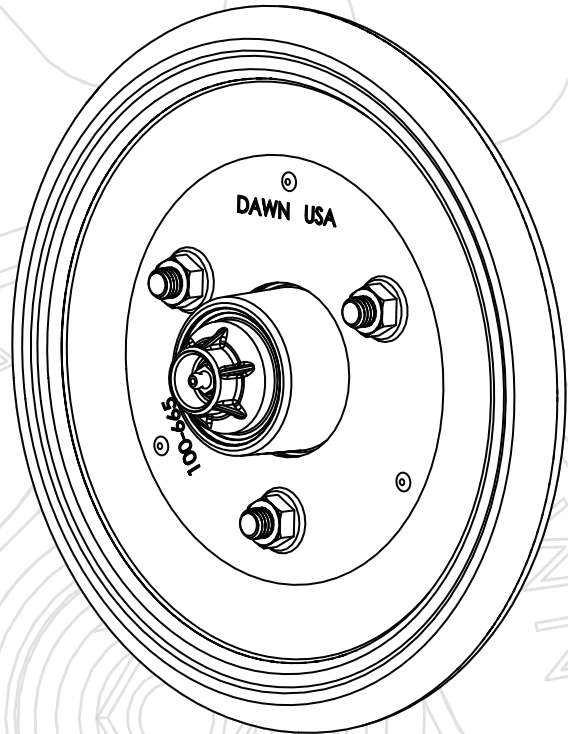
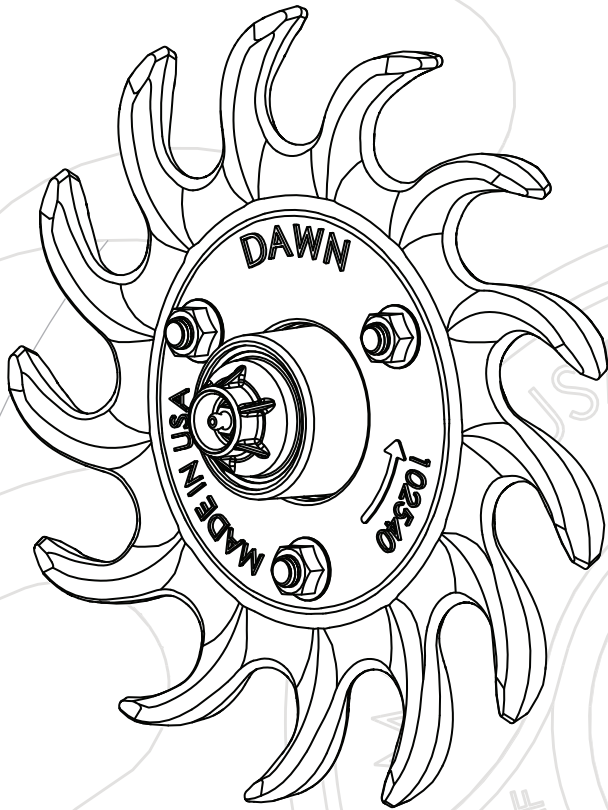

---

**THIS PAGE INTENTIONALLY LEFT BLANK**



# Introduction

## PLEASE CAREFULLY READ THIS MANUAL

It is strongly recommended that you become familiar with all operation and maintenance procedures concerning your Dawn agricultural equipment.

Failure to follow safety recommendations while this implement is in operation, and/or failure to properly store this implement, and/or failure to adequately prepare this implement for transport, could result in equipment damage, personal injury or death. Please make yourself aware of all federal and local laws that may apply to the transport, use and sale of this implement.

## USING THIS MANUAL

All Dawn manuals are named and numbered and should be considered a principal element of the device they accompany. Please ensure this manual is kept in a location not subject to extreme conditions (i.e. excess humidity, hydraulic fluid, exposed to natural elements, etc.). Please ensure that this manual remains with the implement if traded, leased, or sold.

## WARRANTY INFORMATION

All new Dawn Equipment company products carry a limited warranty. Warranty assurances vary by device, and can be found in the appendices of this or any other Dawn Equipment Company users manual. Warranty information is also available upon request by contacting Dawn toll-free at 800.554.0007, or you can request a copy in writing.

Request warranty information by e-mail at [info@dawnequipment.com](mailto:info@dawnequipment.com), or by US post at

Dawn Equipment Company  
PO Box 497  
Sycamore, IL 60178

Dawn Equipment Company prides itself on the manufacture of quality American made row crop tools. Warranties will be honored by Dawn to dealers authorized to sell Dawn Equipment products who, in turn, honor such warranties to the original retail purchaser. Should this equipment be improperly cared for, or should it be modified to change performance beyond OEM specifications, applicable Dawn warranties will become void, and Dawn sponsored implement improvements will not be granted.

## DISCLAIMER

Dawn Equipment Company makes no claim to the safety or reliability of non-Dawn OEM parts or whole goods used in conjunction with Dawn OEM equipment, and shall not be held responsible for any personal injury or property damage, or for any complications with operational performance caused by non-Dawn OEM parts or whole goods used in conjunction with Dawn OEM equipment. Please familiarize yourself with the users manuals and safety recommendations of all non-Dawn OEM equipment.

## WEIGHTS AND MEASURES

All Dawn Equipment Company part and whole good designs adhere to the United states Customary Unit System (Inch-Pound). All measurements in this manual are labeled using only the aforementioned units, unless otherwise explicitly specified.

## ADDITIONAL INFORMATION

Additional information on this, and any other Dawn tool can be found on the web at [www.dawnequipment.com](http://www.dawnequipment.com). You may also contact Dawn for information by phone at **800.554.0007**, or by fax at **815.899.3663**, or by email at [info@dawnequipment.com](mailto:info@dawnequipment.com)



# SAFETY INFORMATION

## GENERAL SAFETY

It is essential that you be able to recognize safety signal words and their associated symbols. Please be alert to any signs posted on your Dawn Equipment Company products, and/or in your users manual. Make sure you have read all safety messages and that you clearly understand the recommended precautions. If you have any questions about any Dawn safety sign, or have further questions about the safety recommendations on this or any other Dawn product, please contact Dawn Equipment Company at 800.554.0007.

**▲ DANGER** - Indicates an imminently hazardous situation that, if not avoided, will result in serious injury or death, and/or property damage

**▲ WARNING** - Indicates a potentially hazardous situation that, if not avoided, will result in serious injury or death, and/or property damage.

**▲ CAUTION** - Indicates a potentially hazardous situation that, if not avoided, may result in minor or moderate injury, and/or property damage.

## REPORTING AN EMERGENCY

Ensure that you have access to a radio or a mobile phone when operating or repairing farm machinery. Working with a partner whenever possible significantly increases the chances of receiving timely emergency care should one party become severely injured, and/or incapacitated.

## MAINTENANCE AND UPKEEP

For safety reasons, it is important to keep your implements in proper working order. Unauthorized modifications to Dawn Equipment Company products may compromise the efficiency and/or safe operation of the product and will void any and all warranties through Dawn Equipment Company. Please read your manual before attempting any repair work to your Dawn tool. If you need to work on your Dawn tool, make sure to support it before partially or fully removing it from the attachment points. Do not adjust your Dawn tools while they are moving.

## PROTECTIVE CLOTHING

Wearing proper attire when working on agricultural equipment is a critical safety precaution. Loose clothing or accessories may become entangled in moving parts causing serious injury or death.

## SAFETY GLASSES/GOGGLES

If you will be using hazardous chemicals, or are striking, cutting or grinding metal make sure you are wearing eye protection.

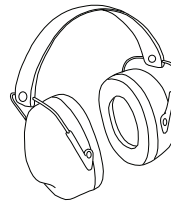
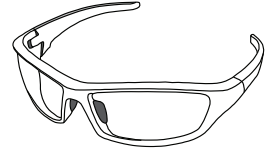

## EARPLUGS / SOUND MUFFLERS

When working around equipment that generates high amplitude sound (ie dryers, vacuums, etc.) ear protection is strongly recommended.

## RESPIRATOR MASK

Carefully read all safety information associated with any chemicals you will be handling. Use a respirator mask when using hazardous chemicals, (ie Insecticides, NH<sub>3</sub>, etc.)

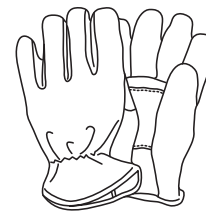
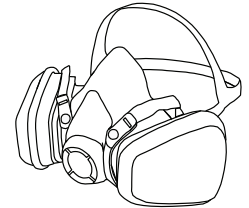

## WORK GLOVES

If working around machinery with sharp edges, or rough metal surfaces, work gloves may prevent a few stitches. Work gloves are inexpensive, and are really worth the investment.

## STEEL-TOED BOOTS

A good pair of steel-toed boots can save your toes. Avoid an unfortunate accident, and protect your feet.

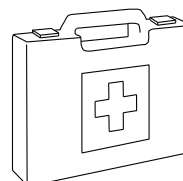

## FIRST AID KIT

In order to minimize the risk of infection, every shop and tractor should have a complete first aid kit.



# PRODUCT INTRODUCTION

## CURVETINE PLACEMENT - STAGGERING WHEELS

Most major planter row unit manufacturers incorporate a two-hole tailpiece design for staggering the closing wheels. When running one Curvetine and one rubber wheel, it is recommended to have the Curvetine in the front hole closest to the planter with the rubber wheel in the rear hole. This is a good idea for shallow planting depth and prevents the Curvetine from becoming too aggressive. If more aggressive action is needed, you may reverse the orientation and run the Curvetine in the rear hole furthest from the planter with the rubber wheel in the leading hole. With either setting, it is important to be mindful of your tailpiece down-pressure. The first (lightest pressure) notch is a good place to start.

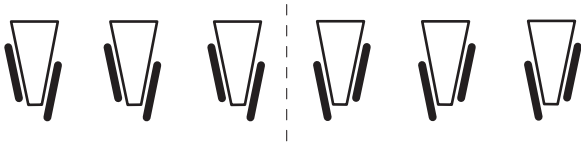

## CLOSING WHEEL SPACING

As a general rule, **the distance between wheels (measured center-to-center) should match your desired planting depth.** Each Curvetine order contains multiple washers as well as a triangular hub spacer, these will allow you to adjust your closing wheel spacing to match your planting depth. The deeper your seed is being placed, the further apart the closing wheels need to be. You may need to adjust your wheel spacing when changing planting depth.

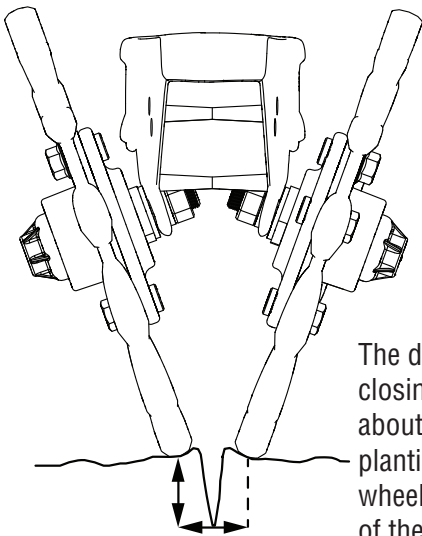

The distance between your closing wheels should be about the same as your planting depth. Make sure wheels sit on the **OUTSIDE** of the furrow.

## HUB ORIENTATION

**Hubs are handed!** Due to the special hub-shaft threading, a left-handed hub can only be installed on the left-hand side of the tailpiece, and a right-handed hub can only be installed on the right-hand side of the tailpiece.

**Left-hand hubs are identified by an "L" marked on the hub shafts. The right-hand hub shaft will show nothing on it.**

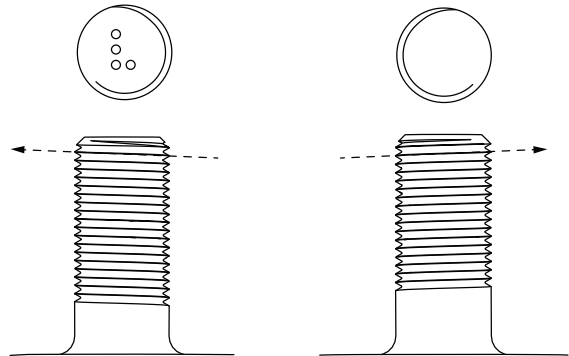

Left-hand threads  
for left-hand hub

Right-hand threads  
for right-hand hub

## WHEEL ORIENTATION

**Curvetines are directional!** Due to the modular design of the M-Series Curvetine, each wheel is symmetrical and can be mounted to either the right-hand or left-handed modular hub. Install Curvetines according to the arrow indicating direction of forward travel.

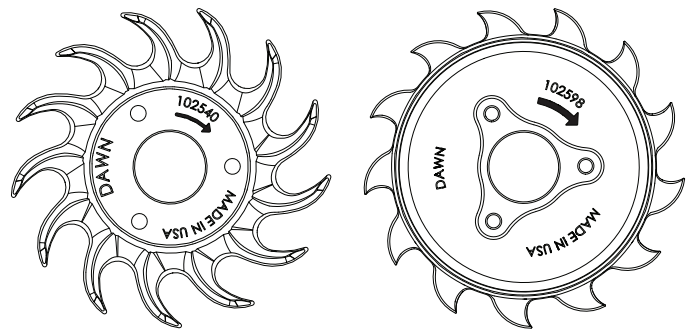

## CARE AND MAINTENANCE

Use Mobil XP222 or similar to grease hubs yearly or every 100 acres/row, whichever comes first. In extremely dusty environments and when liquid fertilizer is being applied with the planter, it may be necessary to grease hubs daily. Grease to purge; **it is not possible to over-grease hubs.** Remove excess grease.



# INSTALLATION

## JOHN DEERE, KINZE & WHITE

For this assembly you will need;

- One open-end 15/16" wrench
- Dawn 1 3/8" hub wrench
- 3/4" socket wrench or impact gun

**NOTE** This installation is intended as a starting point for most growers with seed depths ~2-2.5". To change spacing, add or remove supplied washers as necessary.

### 1 Install Hub

Insert hub shaft through 1 supplied washer, tailpiece, lock washer, and thread into nut. Tighten by placing 15/16" wrench onto nut and turning hub shaft using the supplied Dawn 1 3/8" wrench. To tighten, turn Dawn wrench TOWARDS planter unit. To loosen hub, turn Dawn wrench AWAY from planter unit. Remember that each hub is handed.

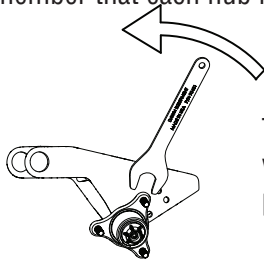

To install hub, turn wrench TOWARDS planter unit.

### 2 Install Curvetine

Place triangular hub spacer between Curvetine and hub, thread on 5/8" flange lock nuts. Remember to install wheel according to the rotational arrow stamped on the outside of the wheel.

### 3 Install Rubber Wheel

Place rubber wheel onto hub, secure 1/2-13" flange lock nuts with 3/4" socket or impact gun.

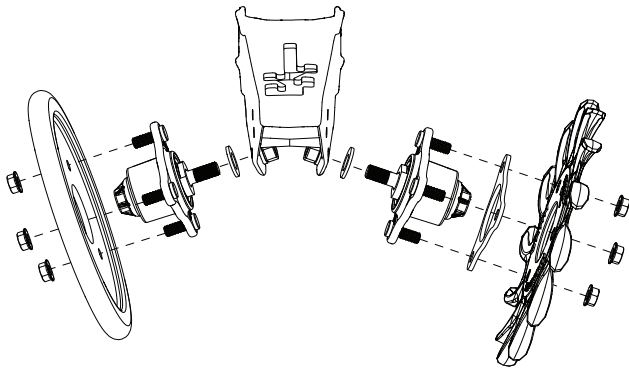

# Appendix - WARRANTY

---

The following warranties with respect to new Dawn Equipment Company ("Dawn") products, excepting as hereafter provided, is made by Dawn to Dealers ("Dealers") authorized by Dawn to sell the products involved and each selling Dealer, in turn, make such warranties to the original retail purchaser ("Purchaser").

## A. Duration and Extent of Warranty

1. Products, except all working, moving and all or any parts subject to wear, except as hereafter provided, which are defective in materials or workmanship as delivered to the Purchaser by Dealer will be repaired by a Dealer or replaced by Dawn, only, as Dawn elects, without charge for materials or labor, if such defect appears in not more than 12 months, or from and after the date of delivery to the Purchase by the Dealer.
2. Dawn warrants that the Trashwheels planter attachment wheels (Dawn part #s 200015, 101550, 102185M-L, 102185M-R) and Curvetine closing wheels (Dawn part # 102540F) will not bend or break during its useful lifetime.
3. Liability of Dawn for defective parts or material is specifically limited to the value of the parts or materials, only.
4. All parts or materials requiring work MUST be returned by delivery to the selling Dealer for repair or for delivery to Dawn within thirty (30) days of occurrence of the defect or failure of the part or material, all freight prepaid by the Dealer upon Dealer warranty form, available by request from Dawn. Upon completion of the warranty work, Dawn will ship parts or material to the Dealer, freight prepaid by Dawn.
5. All decisions by Dawn pertaining to warranty are final.

## B. Warranty Exclusions; Dawn will not be responsible for any of the following;

1. Defects of damage resulting from use, repairs or service performed in a manner not approved by Dawn or from repairs or service performed by someone other than an authorized Dawn Dealer service department (after approval from Dawn) or Dawn to repair or replace the product involved.
2. Defects, damage or failure resulting from any alteration or additions done in a manner not approved by Dawn.
3. Defects, damage or failure or depreciation resulting from wear and tear, accidents, misuses, negligence, improper maintenance or improper protection and storage.

4. INCIDENTAL OR CONSEQUENTIAL DAMAGES, INCLUDING BUT NOT LIMITED TO, LOSS OF PROFITS, LOSS OF TIME, LOSS OF CROPS, INCONVENIENCE, LOSS OF USE OF THE PRODUCT OR OTHER MACHINERY, EQUIPMENT OR VEHICLE USED WITH THE PRODUCTS, COST OF RENTALS OR REPLACEMENT OF THE PRODUCTS OR OTHER COMMERCIAL LOSS.

## C. Remedies Exclusive: NO Other Warranties

The obligations of Dawn and the Dealers are limited to the obligations set forth in this Limited Warranty. THIS LIMITED WARRANTY IS IN LIEU OF ALL OTHER WARRANTIES OF DAWN, AND THE DEALERS, EXPRESSED OR IMPLIED. WARRANTIES BY DAWN OR THE DEALER OF CONDITION QUALITY, MERCHANT ABILITY OR FITNESS FOR A PARTICULAR PURPOSE ARE EXCLUDED, AS ARE ALL OTHER REPRESENTATIONS BY DAWN AND THE DEALERS TO THE PURCHASE OR USER AND ALL OTHER OBLIGATIONS OR LIABILITIES OF DAWN AND THE DEALERS. NO OTHER PERSON IS AUTHORIZED TO GIVE ANY OTHER WARRANTY OR TO ASSUME ANY OTHER LIABILITY ON BEHALF OF DAWN AND THE DEALERS. THIS LIMITED WARRANTY MAY NOT BE TRANSFERRED BY THE PURCHASER TO ANY SUBSEQUENT OWNER.

D. The instruction manual supplied with the Product contains important maintenance and service information. Read the manual and follow the recommendations contained herein. Please remember that failures due to improper maintenance or service are not covered by the Limited Warranty.

Dawn Equipment Company reserves the right to make changes in design or specifications at any time without obligation to purchasers or equipment and components previously sold. This warranty shall not be altered or changed in any way.



# Dawn Parts

1202/1203/1204\_2014\_2

## Dawn Parts Breakdown M-Series Curvetine

Item	Dawn Part #	Item Description
12	9028	Tongue Washer
13	9178	Castelated Nut
14	9019	Cotter Pin
15	90426	O-Ring for Modular Hub
16	102544C	Grease Cap for Modular Hub
17	9806	1/8" Grease Zerk
18	90458	Snap Ring for Modular Hub
19	102567	Triangular Hub Spacer
20	102540F	Curvetine Wheel (1202)
21	400159	Metal Rim and Tire (1203)
22	102598	Gaugetine Wheel (1204)

Item	Dawn Part #	Item Description
1	90428	5/8"-18 Hex Nut RH thread
2	90429	5/8"-18 Hex Nut LH thread
3	9069	Lock Washer
4	9375	3/4 SAE Flat Washer
5	102542R	Hub Shaft RH thread
6	102542L	Hub Shaft LH thread
7	9017	Triple Lip Seal
8	9018	Phenolic Wear Ring
9	9016	Bearing Cone
10	300480	Forged Hub Press Assy.
11	9007-R1	1/2"-13 Flange Lock Nut

\* Included with hub replacement kit 400156R/L  
must specify RIGHT or LEFT

