

DAWN®

GFX FLOATING TRASHWHEEL® REMOTE-ADJUST HYDRAULIC ROW CLEANER MODEL 5010



5010 model shown
with 12.75" Trashwheels®
and depth bands

- Bulkhead connection plate keeps your hydraulic hoses tidy, and out of the way.
- Heavy-duty drop-forged support arms and row cleaners.
- Trashwheel® hubs run on **TIMKEN®** roller bearings.
- Fits most John Deere, Kinze, White and Case planters.
- Trashwheel® guaranteed against bending or breaking.

The frame mounted, trailing-arm Gfx Row Cleaner follows ground contours, without gouging, even in very difficult field conditions. Mounting the row cleaner to the toolbar allows for independent control over the row cleaner and planter row unit. Planter attachments mounted to the planter row unit may affect spacing by jarring the seed meter, and emergence by causing irregularity in opener depth, as the unit encounters an infield obstacle.

Plus, an integral hydraulic accumulator prevents the row cleaner from affecting the action of nearby units, and also absorbs pressure spikes from impact with infield obstacles.



Model #	Description
5010-12.75	GFX ROW CLEANER WITH 12.75" TRASHWHEELS® Available with optional Depth Bands.
5010-14	GFX ROW CLEANER WITH 14" TRASHWHEELS® Available with optional Depth Bands.
400124	FX ELECTRO-HYDRAULIC PRIMARY CONTROL KIT One kit per planter is required to control GFX units.
400140	FX ELECTRO-HYDRAULIC SECONDARY CONTROL KIT Add multiple sections of control without using extra hydraulic ports.

800.554.0007
dawnequipment.com



MADE
IN USA

GROUND EFFECTS

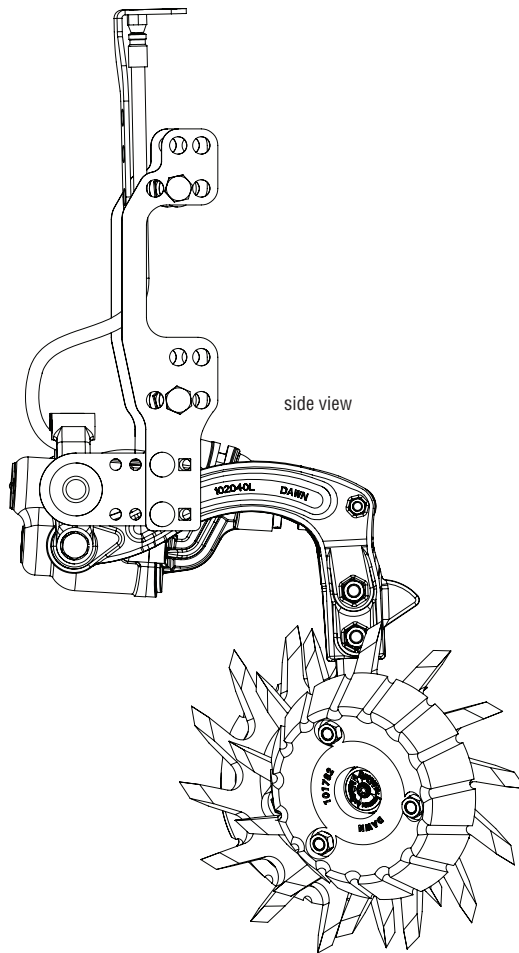
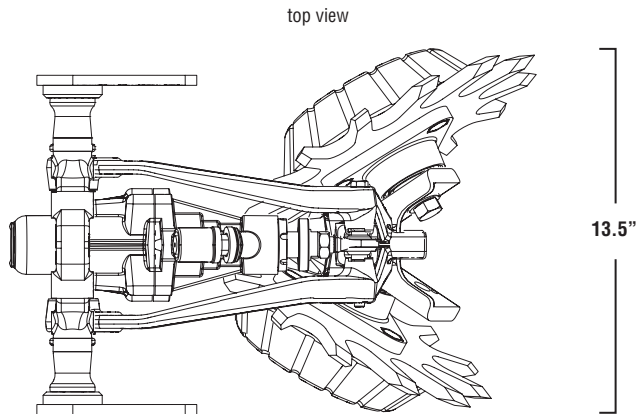
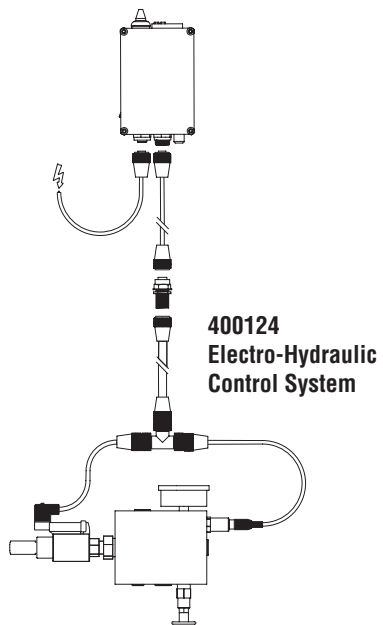
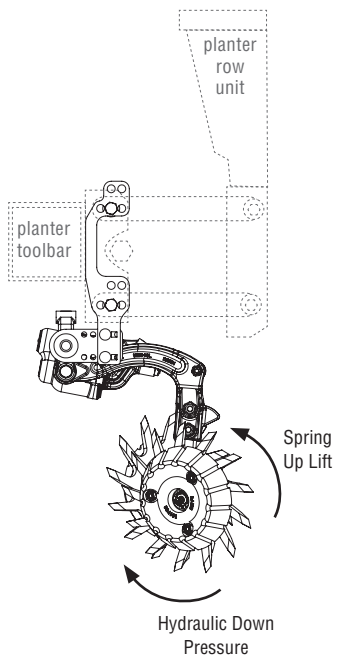

GFX with 12.75" Trashwheel®

Model 5010DB-12.75"

Length 20 in.

Width 13.5 in.

Weight 75 lbs.

Down Pressure 0-120 lbs

Hyd. Pressure 800-2000 psi

Range of Travel ± 5 in.

GFX with 14" Trashwheel®

Model 5010DB

Length 20 in.

Width 14.5 in.

Weight 80 lbs.

Down Pressure 0-120 lbs

Hyd. Pressure 800-2000 psi

Range of Travel ± 5 in.

Hydraulic Features

20" Row Hose p/n 400126

30" Row Hose p/n 400125

Analog p/n 400124

©2013 Dawn Equipment Company Inc. products are covered by one or more of the following US Patents: 4785890 LIC, 5129282, 5240080, 5337832, 5346020, 5477792, 5479868, 5443023, 5479992, 5485886, 5497837, 5499683, and 5542362. Other patents pending. DAWN, TRASHWELL, TRASHWHEEL II, VARIWHEEL, CURVETINE, CURVETINE XR, CURVETINE II, POWERLINK, SUPERLINK, AND QUICK-LIFT are registered trademarks of Dawn Equipment Company. Prices effective: June 1 2013. Prices and specifications subject to change without notice. All prices are FOB Dawn Factory. All rights reserved. Printed in the USA.